

Features

- **46uA (Typ) Low Power Consumption**
- **Fast, 70ns Propagation Delay**
- **Single-Supply Operation from +1.8V ~ +5.5V**
- **Low Offset Voltage: 3mV (Max)**
- **Rail-to-Rail Input and Output**
- **CMOS/TTL-Compatible Output**
- **Internal Hysteresis for Clean Switching**
- **No Phase Reversal for Overdriven Inputs**
- **Operating Temperature: -40°C ~ +85°C**
- **Small Package:**
GSV331 Available in SOT23-5 and SC70-5 Packages
GSV332 Available in SOP-8 and MSOP-8 Packages

General Description

The GSV331 is low-power, high-speed comparator with internal hysteresis, optimized for systems powered from a 3V or 5V supply. The device features high-speed response, low-power consumption, low offset voltage, and rail-to-rail input and output range.

Propagation delay is 70ns (100mV overdrive), while supply current is 46uA per comparator. The internal input hysteresis eliminates output switching due to internal input noise voltage. The maximum input offset voltage is 3mV, and the operating range is from 1.8V to 5.5V.

All devices are specified for the temperature range of -40°C to +85°C. The GSV331 single is available in Green SC70-5 and SOT23-5 packages. The GSV332 dual is available in Green SOP-8 and MSOP-8 packages.

Applications

- Alarm and Monitoring Circuits
- Peak and Zero-crossing Detectors
- Logic Level Shifting or Translation
- RC Timers
- Window Comparators
- IR Receivers
- Portable Systems

Pin Configuration

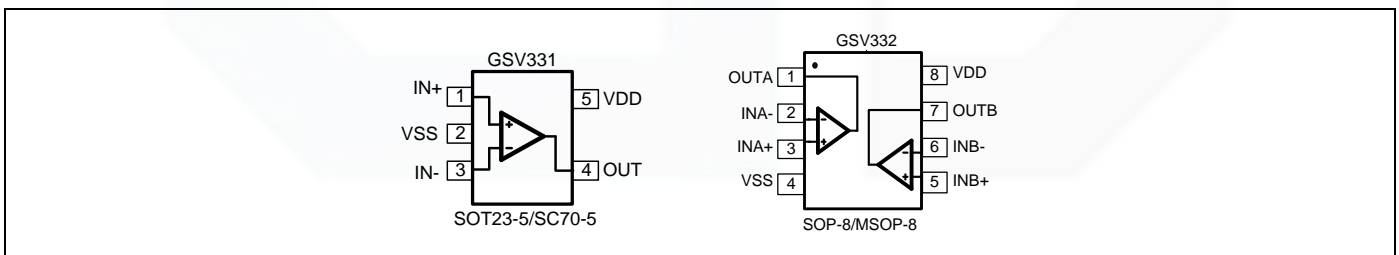

Figure 1. Pin Assignment Diagram

Absolute Maximum Ratings

Condition	Min	Max
Power Supply Voltage (V_{DD} to V_{SS})	-0.5V	+7.5V
Analog Input Voltage ($IN+$ or $IN-$)	$V_{SS}-0.5V$	$V_{DD}+0.5V$
PDB Input Voltage	$V_{SS}-0.5V$	+7V
Operating Temperature Range	-40°C	+85°C
Junction Temperature	+160°C	
Storage Temperature Range	-55°C	+150°C
Lead Temperature (soldering, 10sec)	+260°C	
Package Thermal Resistance ($T_A=+25^\circ\text{C}$)		
SOP-8, θ_{JA}	125°C/W	
MSOP-8, θ_{JA}	216°C/W	
SOT23-5, θ_{JA}	190°C/W	
SC70-5, θ_{JA}	333°C/W	
ESD Susceptibility		
HBM	4KV	
MM	300V	

Note: Stress greater than those listed under Absolute Maximum Ratings may cause permanent damage to the device. This is a stress rating only and functional operation of the device at these or any other conditions outside those indicated in the operational sections of this specification are not implied. Exposure to absolute maximum rating conditions for extended periods may affect reliability.

Package/Ordering Information

MODEL	CHANNEL	ORDER NUMBER	PACKAGE DESCRIPTION	PACKAGE OPTION	MARKING INFORMATION
GSV331	Single	GSV331-CR	SC70-5	Tape and Reel,3000	V331
		GSV331-TR	SOT23-5	Tape and Reel,3000	V331
GSV332	Dual	GSV332-SR	SOP-8	Tape and Reel,4000	GSV332
		GSV332-MR	MSOP-8	Tape and Reel,3000	GSV332

Electrical Characteristics

(At $V_S = +5V$, $V_{CM} = 0V$, $C_L = 15pF$, and $T_A = +25^\circ C$, unless otherwise noted.)

PARAMETER	SYMBOL	CONDITIONS				
			TYP	MIN	MAX	UNITS
INPUT CHARACTERISTICS						
Input Offset Voltage	V_{OS}	$V_{CM} = 0V$	0.5		3	mV
Input Bias Current	I_B		6			pA
Input Offset Current	I_{OS}		4			pA
Input Hysteresis	V_{hys}		6			mV
Common-Mode Voltage Range	V_{CM}	$V_S = 5.5V$	-0.1 to +5.6			V
Common-Mode Rejection Ratio	CMRR	$V_S = 5V$, $V_{CM} = 0V$ to $5V$	70	50		dB
OUTPUT CHARACTERISTICS						
Output Voltage Swing from Rail	V_{OH}	$V_S=5V$, $I_O = 1mA$	$V_S - 0.05$		$V_S - 0.3$	V
	V_{OL}		57		300	mV
Output Short-Circuit Current	I_{SOURCE}	$V_S = 5V$, Out to $V_S/2$	35			mA
	I_{SINK}		33			
POWER SUPPLY						
Operating Voltage Range			1.8			V
			5.5			V
Power Supply Rejection Ratio	PSRR	$V_S = +1.6V$ to $+5.5V$, $V_{CM} = 0V$	75	60		dB
Quiescent Current / Comparator	I_Q		46			uA
DYNAMIC PERFORMANCE (CL = 15pF)						
Propagation Delay (Low to High)	T_{dLH}	$V_S = 3V$, Overdrive = 10mV	98.6			ns
		$V_S = 3V$, Overdrive = 100mV	77.5			ns
Propagation Delay (High to Low)	T_{dHL}	$V_S = 3V$, Overdrive = 10mV	114.7			ns
		$V_S = 3V$, Overdrive = 100mV	59.4			ns
Rise Time	T_r	$V_S = 3V$, Overdrive = 10mV	5			ns
		$V_S = 3V$, Overdrive = 100mV	5			ns
Fall Time	T_f	$V_S = 3V$, Overdrive = 10mV	5			ns
		$V_S = 3V$, Overdrive = 100mV	5			ns

Typical Performance characteristics

At $T_A=+25^{\circ}\text{C}$, $V_S=+5\text{V}$, and $C_L=15\text{pF}$, unless otherwise noted.

Supply Current vs. Temperature

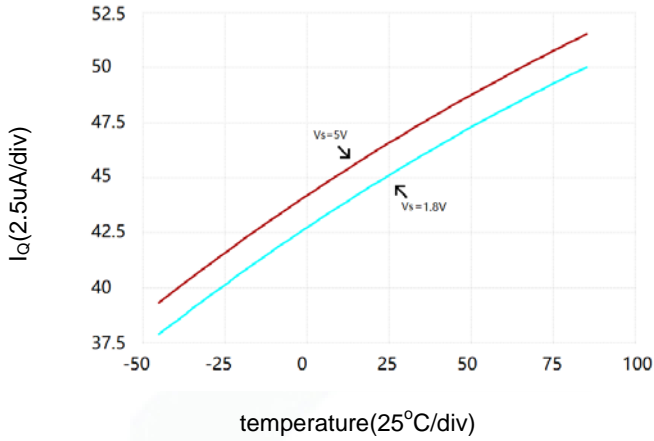

Sinusoid Response at 0.2MHz

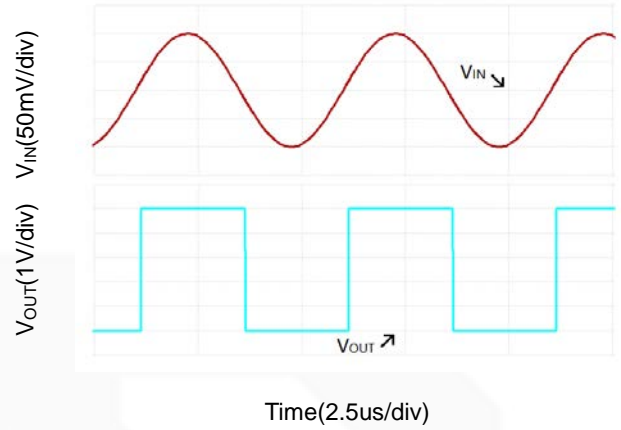

Output Short-Circuit (Source) Current vs. Temperature

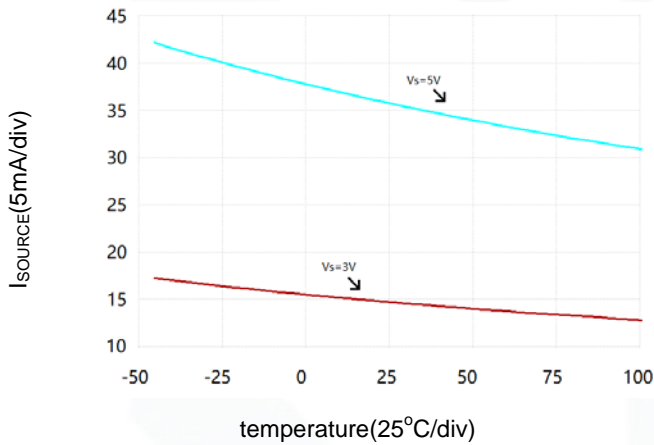

Output Short-Circuit (Sink) Current vs. Temperature

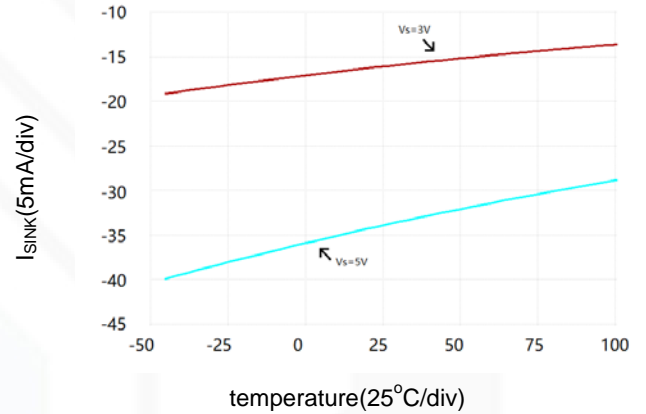

Propagation Delay (L-H&H-L)

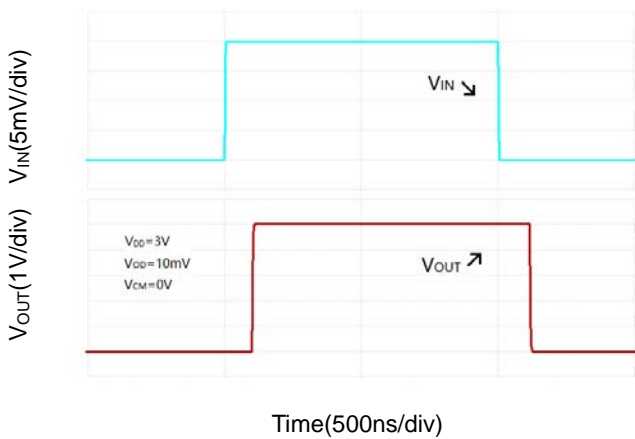

Propagation Delay (L-H&H-L)

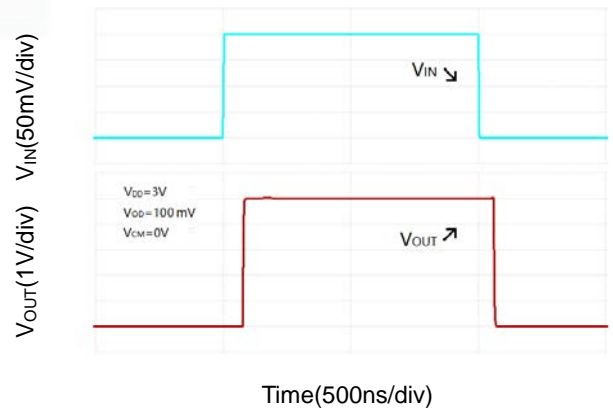

Application Note

Size

GSV331 comparator is low-power, high-speed and suitable for a wide range of general-purpose applications. The small footprints of the GSV331 package saves space on printed circuit boards and enable the design of smaller electronic products. The GSV331 interfaces directly to CMOS and TTL logics.

Power Supply Bypassing and Board Layout

GSV331 operates from a single 1.8V to 5.5V supply or dual $\pm 0.9V$ to $\pm 2.75V$ supplies. For best performance, a 0.1 μF ceramic capacitor should be placed close to the V_{DD} pin in single supply operation. For dual supply operation, both V_{DD} and V_{SS} supplies should be bypassed to ground with separate 0.1 μF ceramic capacitors.

Low Supply Current

The low supply current (typical 46 μA per channel) of GSV331 will help to maximize battery life. They are ideal for battery powered systems.

Operating Voltage

GSV331 operates under wide input supply voltage (1.8V to 5.5V). In addition, all temperature specifications apply from $-40^{\circ}C$ to $+85^{\circ}C$. Most behavior remains unchanged throughout the full operating voltage range. These guarantees ensure operation throughout the single Li-Ion battery lifetime

Rail-to-Rail Input

The input common-mode range of GSV331 extends 100mV beyond the supply rails ($V_{SS}-0.1V$ to $V_{DD}+0.1V$). This is achieved by using complementary input stage. For normal operation, inputs should be limited to this range.

Internal Hysteresis

Because of noise or undesired parasitic feedback, high-speed comparators oscillate in the linear region. Oscillation tends to occur when the voltage on one input is at or equal to the voltage on the other input. The GS806 family eliminates this undesired oscillation by integrating an internal hysteresis of 6mV.

The hysteresis in a comparator creates two trip points: one for the rising input voltage and one for the falling input voltage (Figure 2). The difference between two trip points is the hysteresis, while the average of two trip points is the offset voltage. When the comparator's input voltages are equal, the hysteresis effectively causes one comparator input voltage to move quickly past the other, thus taking the input out of the region where oscillation occurs.

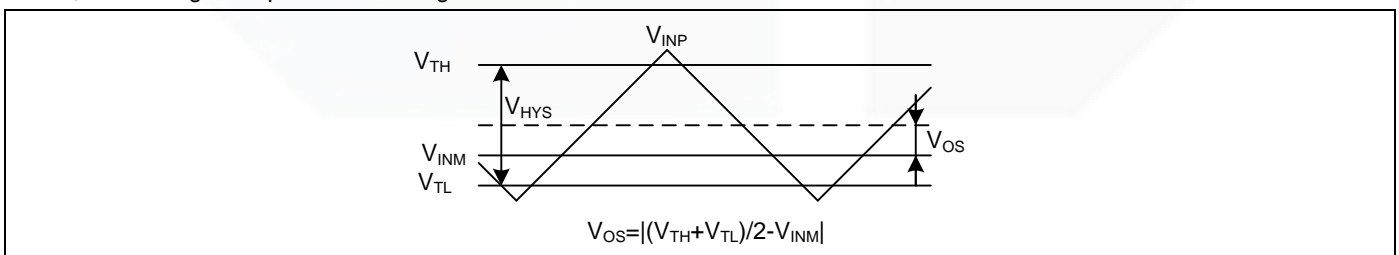

Figure 2. Comparator's hysteresis and offset

External Hysteresis

Greater flexibility in selecting hysteresis is achieved by using external resistors. Hysteresis reduces output chattering when one input is slowly moving past the other.

Non-Inverting Comparator with Hysteresis

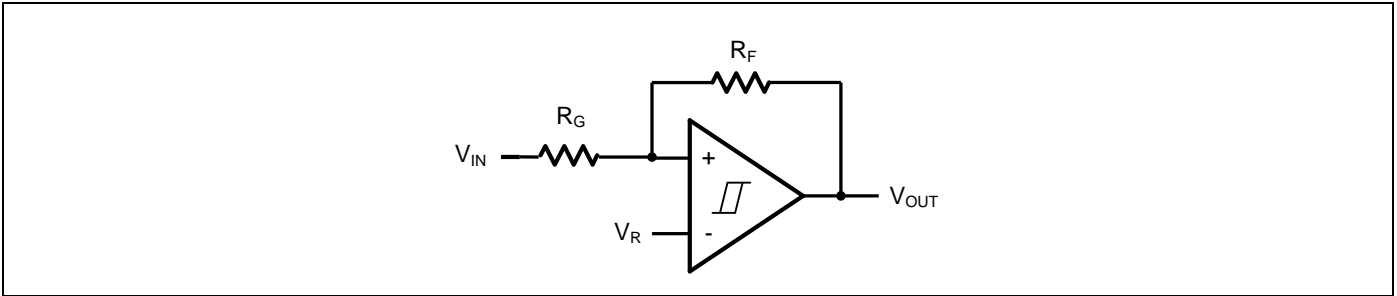

Figure 3. Non-Inverting Comparator with Hysteresis

A non-inverting comparator with hysteresis requires a two-resistor network, as shown in Figure 3 and a voltage reference (V_R) at the inverting input.

$$V_{TH} = \frac{R_G + R_F}{R_F} \times V_R$$

$$V_{TL} = \frac{R_G + R_F}{R_F} \times V_R - \frac{R_G}{R_F} \times V_{DD}$$

$$V_{HYS} = \frac{R_G}{R_F} \times V_{DD}$$

Inverting Comparator with Hysteresis

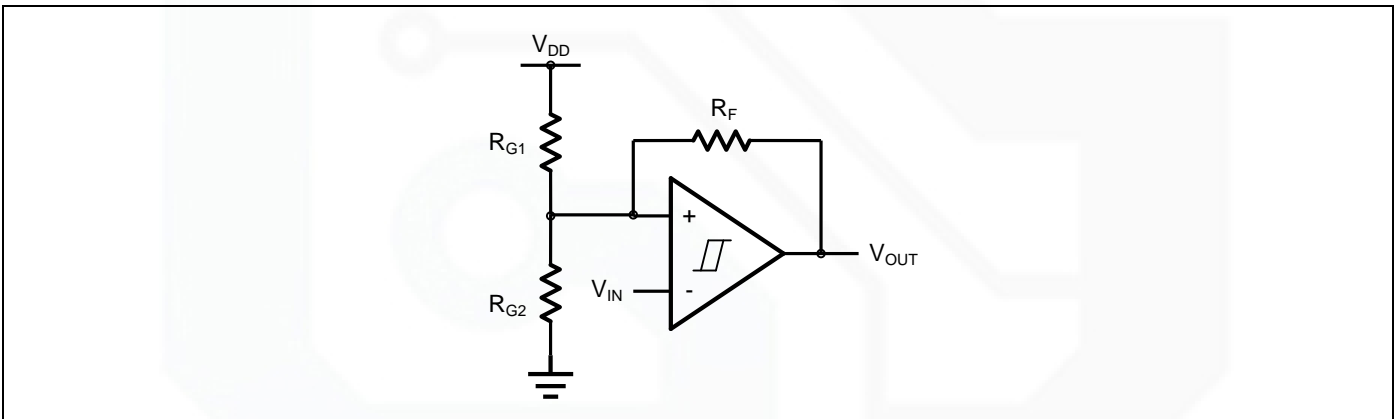

Figure 4. Inverting Comparator with Hysteresis

The inverting comparator with hysteresis requires a three-resistor network that is referenced to the comparator supply voltage (V_{DD}), as shown in Figure 4.

$$V_{TH} = \frac{R_{G2}}{R_{G1} \parallel R_F + R_{G2}} \times V_{DD}$$

$$V_{TL} = \frac{R_{G2} \parallel R_F}{R_{G2} \parallel R_F + R_{G1}} \times V_{DD}$$

$$V_{HYS} = \frac{R_{G1} \parallel R_{G2}}{R_{G1} \parallel R_{G2} + R_F} \times V_{DD}$$

Typical Application Circuits

Line Receiver

A Line Receiver using GSV331 is shown in Figure 5. Resistors R_{G1} and R_{G2} set the bias point at the comparator's inverting input. R_{IN} should be same as $R_{G1}||R_{G2}$ to get a better match. GSV331 detects the voltage of the Coax Line, and outputs logic high or logic low quickly with no glitch.

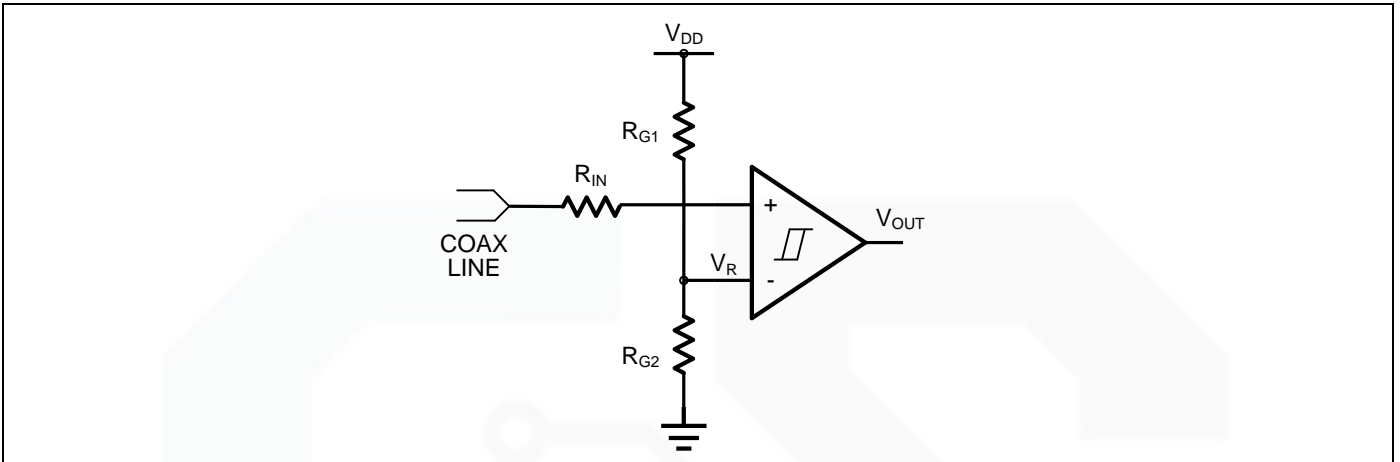

Figure 5. Line Receiver

IR Receiver

GSV331 is an ideal candidate to be used as an infrared receiver shown in Figure 6. The infrared photo diode creates a current relative to the amount of infrared light present. The current creates a voltage across R_{IN} . When this voltage level cross the voltage applied by the voltage divider to the inverting input, the output transitions. Optional R_F provides additional hysteresis for noise immunity.

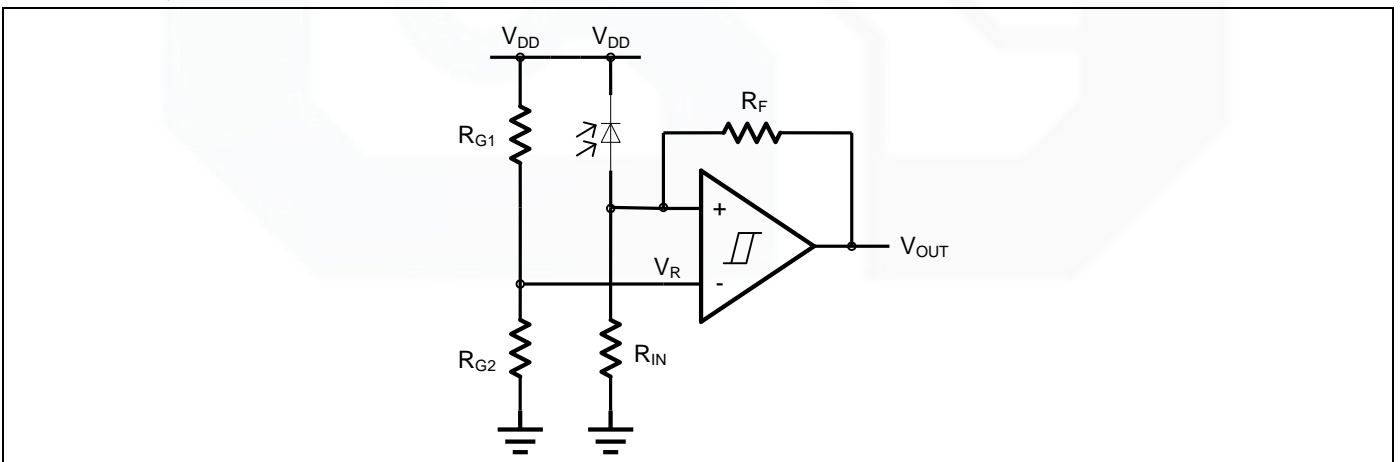

Figure 6. IR Receiver

Oscillator

A oscillator using GSV331 is shown in Figure 7. Resistors R_{G1} and R_{G2} set the bias point at the comparator's inverting input. The period of oscillator is set by the time constant of R_C and C_{IN} . The maximum frequency is limited by the large signal propagation delay of the comparator. GSV331 is low propagation delay guarantees the high frequency oscillation.

If $R_{G1}=R_{G2}=R_F$, then the frequency of the oscillator is:

$$f_{osc} = \frac{1}{2 \times \ln 2 \times R_C \times C_{IN}}$$

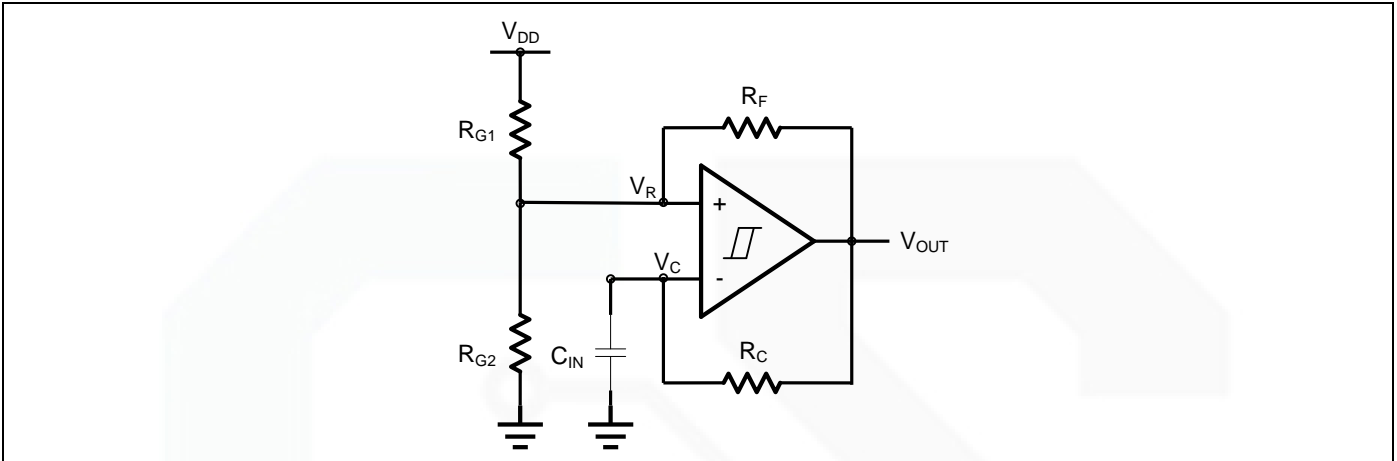
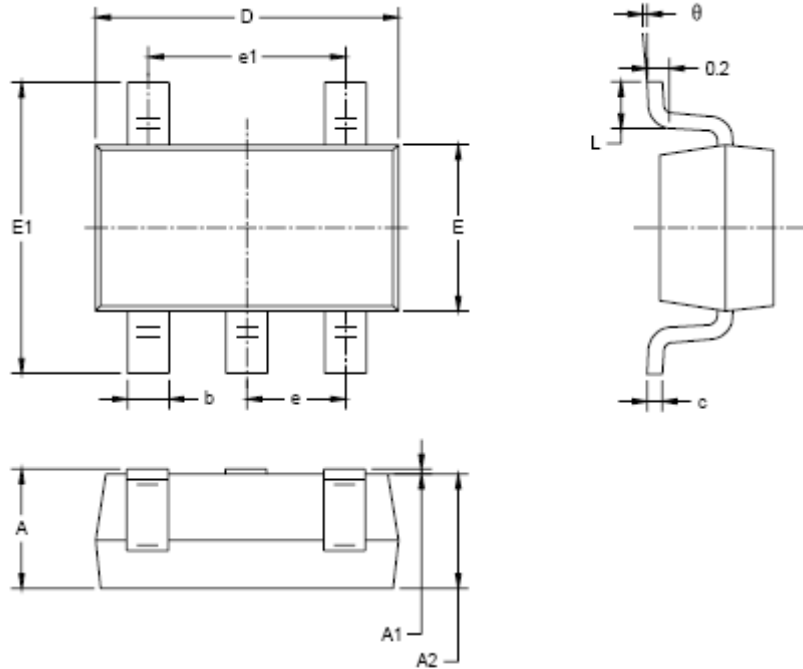

Figure 7. Oscillator

Package Information

SOT23-5



Symbol	Dimensions In Millimeters		Dimensions In Inches	
	MIN	MAX	MIN	MAX
A	1.050	1.250	0.041	0.049
A1	0.000	0.100	0.000	0.004
A2	1.050	1.150	0.041	0.045
b	0.300	0.500	0.012	0.020
c	0.100	0.200	0.004	0.008
D	2.820	3.020	0.111	0.119
E	1.500	1.700	0.059	0.067
E1	2.650	2.950	0.104	0.116
e	0.950 BSC		0.037 BSC	
e1	1.900 BSC		0.075 BSC	
L	0.300	0.600	0.012	0.024
θ	0°	8°	0°	8°

SC70-5

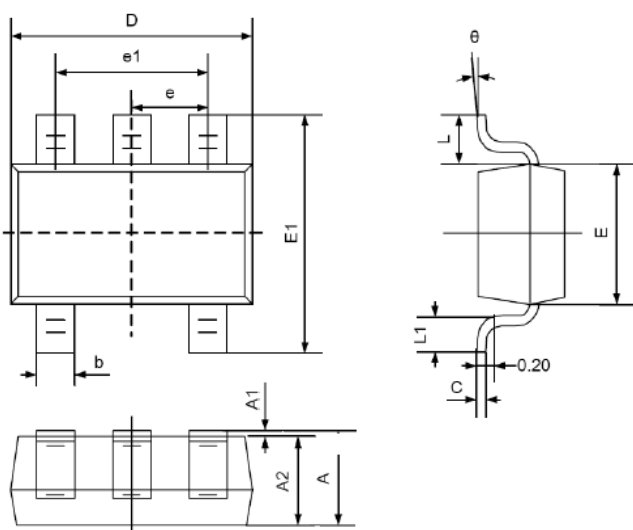

Symbol	Dimensions In Millimeters		Dimensions In Inches	
	Min	Max	Min	Max
A	0.900	1.100	0.035	0.043
A1	0.000	0.100	0.000	0.004
A2	0.900	1.000	0.035	0.039
b	0.150	0.350	0.006	0.014
C	0.080	0.150	0.003	0.006
D	2.000	2.200	0.079	0.087
E	1.150	1.350	0.045	0.053
E1	2.150	2.450	0.085	0.096
e	0.650TYP		0.026TYP	
e1	1.200	1.400	0.047	0.055
L	0.525REF		0.021REF	
L1	0.260	0.460	0.010	0.018
θ	0°	8°	0°	8°



MSOP-8

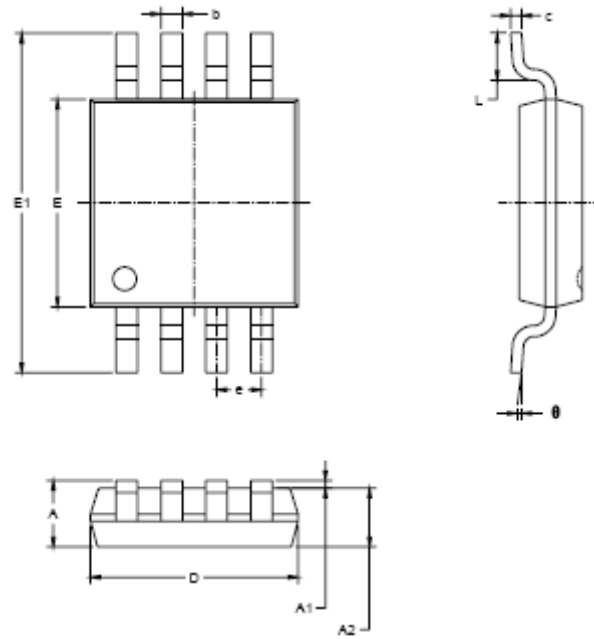

Symbol	Dimensions In Millimeters		Dimensions In Inches	
	MIN	MAX	MIN	MAX
A	0.620	1.100	0.032	0.043
A1	0.020	0.150	0.001	0.008
A2	0.750	0.950	0.030	0.037
b	0.250	0.380	0.010	0.015
c	0.090	0.230	0.004	0.009
D	2.900	3.100	0.114	0.122
E	2.900	3.100	0.114	0.122
E1	4.750	5.050	0.187	0.199
e	0.650 BSC		0.026 BSC	
L	0.400	0.900	0.016	0.031
θ	0°	8°	0°	8°

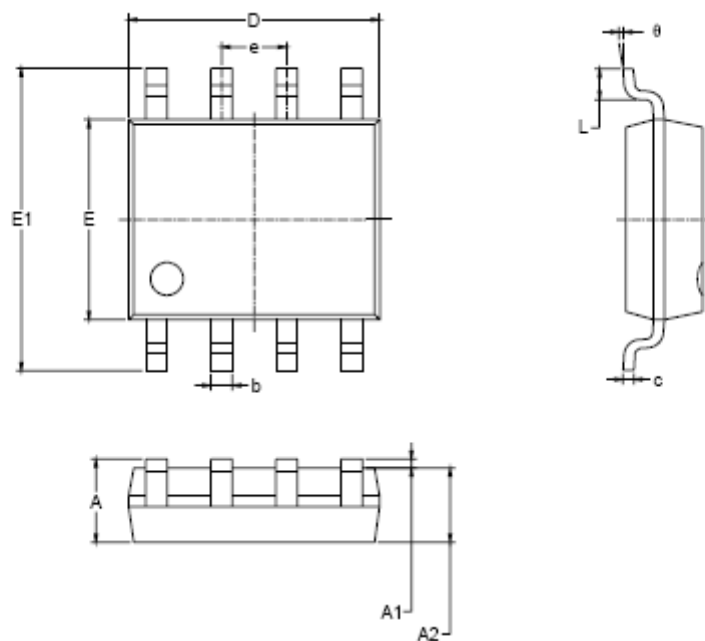

Symbol	Dimensions In Millimeters		Dimensions In Inches	
	MIN	MAX	MIN	MAX
A	1.350	1.750	0.053	0.069
A1	0.100	0.250	0.004	0.010
A2	1.350	1.550	0.053	0.061
b	0.330	0.510	0.013	0.020
c	0.170	0.250	0.008	0.010
D	4.700	5.100	0.185	0.200
E	3.800	4.000	0.150	0.157
E1	5.800	6.200	0.228	0.244
e	1.27 BSC		0.050 BSC	
L	0.400	1.270	0.016	0.050
θ	0°	8°	0°	8°